

**STA-RITE**  
INDUSTRIES, INC.  
a **WICOR** company

# SWIMQUIP HIGH RATE SAND FILTER OWNER'S MANUAL

## INSTALLATION OPERATION PARTS

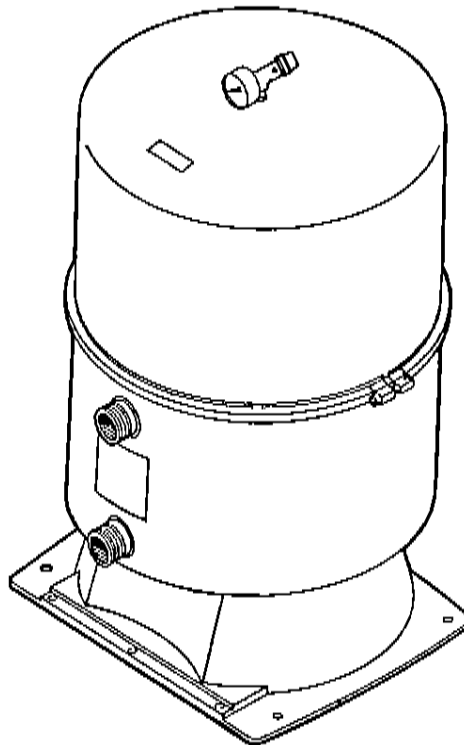

### MODELS

**HRS16-01**

**HRS20-01**

**HRS24-01**

This manual should be furnished to the end user of this filter; its use will reduce service calls and chance of injury and will lengthen filter life.

STA-RITE INDUSTRIES, INC., 293 WRIGHT ST., DELAVAN, WI 53115 (414) 728-5551

Los Angeles, CA ■ Orlando, FL ■ Boise, ID ■ Flanders, NJ ■ Oklahoma City, OK ■ Memphis, TN ■ Delavan, WI

Printed in U.S.A. Copyright © Sta-Rite Industries, Inc., 1989

S229 (1/89)

C8

# HIGH RATE HRS FILTERS

To avoid unneeded service calls, prevent possible injuries, and get the most out of your filter, READ THIS MANUAL CAREFULLY!

The Sta-Rite 'HRS' Series High Rate Filter:

- Is designed to filter water for swimming pools.
- Is an excellent performer; durable, reliable.

## Table of Contents

Safety Instructions ..... 2-3

General Information/Specifications ..... 3-4

Installation ..... 5

Initial Filling/Startup ..... 6

Filter Disassembly/Assembly ..... 6-7

Filter Backwash Procedure ..... 7

Maintenance ..... 8

Winterizing/Troubleshooting Guide ..... 9

Repair Parts List ..... 10-11

Warranty ..... 12

## READ AND FOLLOW SAFETY INSTRUCTIONS!



**▲ DANGER**

**▲ WARNING**

**▲ CAUTION**

This is the safety-alert symbol. When you see this symbol on your filter or in this manual, look for one of the following signal words and be alert to the potential for personal injury:

**DANGER** warns about hazards that **will** cause serious personal injury, death or major property damage if ignored.



**WARNING** warns about hazards that **can** cause serious personal injury, death or major property damage if ignored.

**CAUTION** warns about hazards that **will** or **can** cause minor personal injury or property damage if ignored.

The label **NOTICE** indicates special instructions which are important but not related to hazards.

**Carefully read and follow all safety instructions in this manual or on filter.**

Keep safety labels in good condition.  
Replace missing or damaged safety labels.

	<b>⚠ DANGER</b>	<b>BEFORE WORKING ON FILTER:</b>
	If filter clamp is adjusted under pressure, tank lid will blow off, causing severe injury or major property damage.	1. Stop pump. 2. Open air release valve. 3. Release all pressure from system.
	<b>⚠ WARNING</b>	<b>BEFORE WORKING ON PUMP OR MOTOR:</b>
	Filter pumps require hazardous voltage which can shock, burn, or cause death.	Disconnect power to motor.

### GENERAL INFORMATION

- Clean a new pool as well as possible before filling pool and operating filter. Excess dirt and large particles of foreign matter in the system can cause serious damage to the filter and pump.
- Keep pool water pH at recommended level (7.2 to 7.6) to avoid deterioration of the stainless steel filter tank. Although the tank is stainless, it is not corrosion proof and can be attacked by acids and caustics.

**⚠ DANGER**

Hazardous pressure. Can cause severe injury or major property damage from tank blow up. Release all pressure and read instructions before working on filter.

**⚠** If filter is improperly disassembled or assembled, it will explode under pressure! To avoid danger of severe injury or major property damage, always follow service instructions in this manual when working on filter!

**⚠** NEVER operate this filter system at more than 50 pounds per square inch (50 PSI) pressure!

#### Recommended Sand Grades:

(Use only one of the recommended grades; DO NOT use a finer grade than recommended.)

Ottawa-Flintshot (#30-40)	Penn. Glass - #20 Q-ROK
Ottawa-Special Course (#40-50)	Ottawa Filtration Silica-Silurian
Mystic-#20 Quartz Angular	Ottawa Filtration Silica-Flintshot (R)
Whitehead-Sub-angular Les- (.40/.45mm)	Ottawa Silica-Sawing (formerly Special Course)
AGSCO-Quartzite #3	Mystic White-#20, (.49mm) Pool
Crystal-Silica #20	
Crystal-Silica #20 (Western U.S.)	Filter Sand N.E.

# SPECIFICATIONS

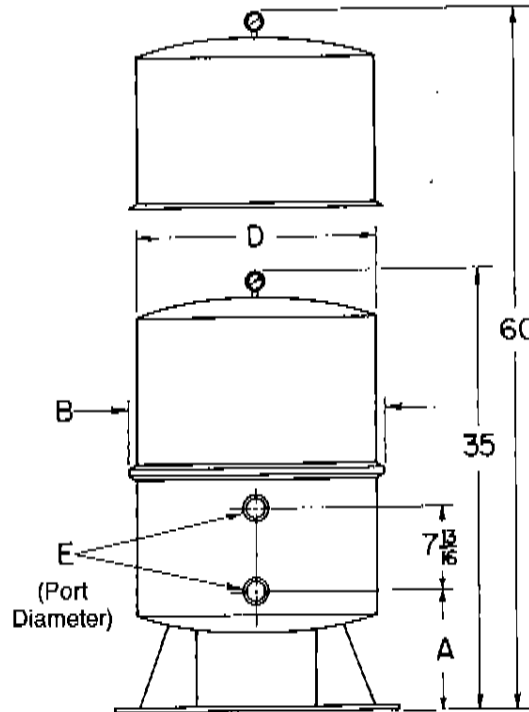

FIGURE 1A

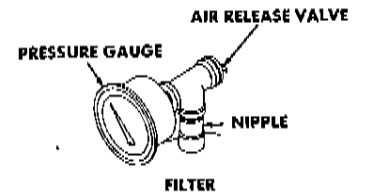

FIGURE 2

CAUTION: To ensure accurate gauge readings and avoid air entrapment, mount air release valve assembly as shown.

TABLE I - SPACE REQUIREMENTS

Model No.	A	B	D	E*
HRS16-01	8-7/16	17-1/4	16	1-1/2
HRS20-01	8-7/16	21-1/4	20	1-1/2
HRS24-01	9	25-1/4	24	2

\* (Port Diameter)

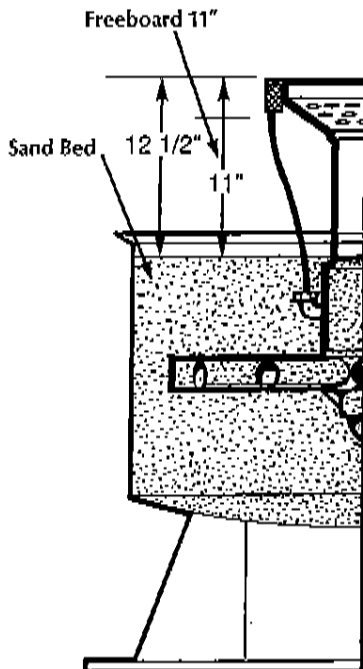

FIGURE 1B

TABLE II - FILTER SPECIFICATIONS AND OPERATING INFORMATION

Filter Model:	HRS16-01	HRS20-01	HRS24-01
Filter Area	1.4 Sq. Ft.	2.2 Sq. Ft.	3.1 Sq. Ft.
Flow Rate	20-28 GPM	33-44 GPM	47-62 GPM
Max. Operating Pressure	50 PSI	50 PSI	50 PSI
Freeboard**	11"	11"	11"
Turnover in Hours:			
6 Hours	10,000 Gal.	16,000 Gal.	22,000 Gal.
8 Hours	13,500 Gal.	21,000 Gal.	30,000 Gal.
10 Hours	16,500 Gal.	26,500 Gal.	37,000 Gal.
Qty. of Media Required:			
Cu. Ft.	1-3/4	2	2-1/2
Weight (Pounds)	175	200	250

\*\* Freeboard is the clear vertical distance between top of filter media and lowest outlet of upper distribution system.

NOTE: 1 cubic foot of sand equals approximately 100 lbs. DO NOT use a finer grade of sand than recommended. See Table II.

## INSTALLATION

Have filter installed only by qualified, licensed personnel.

### Filter mount must:

- Provide weather and freezing protection.
- Provide space and lighting for easy access for routine maintenance. (See Figure 1A and Table I, Page 4, for space requirements.)
- Provide adequate drainage.
- Be on a level surface and less than three feet above water level.
- Be as close to pool as possible to reduce line loss from pipe friction.

### Piping:

- All piping must conform to local and state plumbing and sanitary codes.
- Use Teflon tape or Plasto-Joint Stik<sup>1</sup> on all male connections of pipe and fittings. Do not use pipe compounds on plastic pipe; it may cause stress cracking of the pipe.
- Support pipe independently to prevent strains on filter or valve.
- Use 1½" or two inch pipe to reduce pressure losses as much as possible.

**NOTICE:** Filter may be located away from pool, but for adequate flow large pipe may be needed. Check local codes for remote installation.

- Fittings restrict flow; for best efficiency use fewest possible fittings.
- Keep piping tight and free of leaks; pump suction line leaks may cause trapped air in filter tank or loss of prime at pump; pump discharge line leaks may show up as dampness or jets of water.
- **NOTICE:** Overtightening can crack filter ports.

### Valves:

- A check valve installed ahead of filter inlet will prevent contaminants from draining back into pool.
- A check valve installed between filter and heater will prevent hot water from heater from backing up into filter and deforming filter elements.
- Install Sta-Rite Two Position Slide Valve or Multiport Selector Valve with filter. Filter and valve are furnished with union connections. **DO NOT** use pipe sealants on union collar (nut), (See Table III)
- Use care before assembly not to damage union sealing surfaces or "O" Ring.
- Install union "O" Rings in groove; tighten union collar hand tight.

### Electrical:

- Filter grounding and bonding must meet local and/or National Electrical Code. All wiring, grounding and bonding of associated equipment must meet local and/or National Electrical Code standards.

### Assembly:

- See Pages 6 and 7 for assembly/filling instructions.

<sup>1</sup> Lake Chemical Co., Chicago, IL

TABLE III - Sta-Rite valves for use with HRS-01 filters.

Port Size	Part Number
1½" 2"	Multi-port WC212-143P WC212-144P
1½" 2"	Brass Slide WC212-135D WC212-136D
2"	Plastic Slide WC212-134D

**CAUTION**

**DANGER**



Hazardous pressure.  
Can cause severe  
injury or major  
property damage  
from tank blow up.  
Release all pressure  
and read instructions  
before working on  
filter.

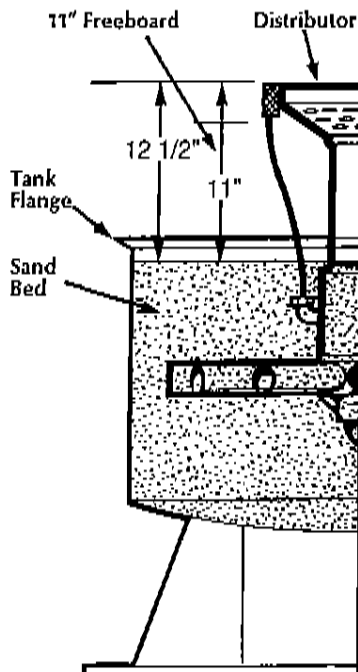

Figure 3 - Fill sand  
bed as shown

**CAUTION**

## FILTER DISASSEMBLY/ ASSEMBLY PROCEDURE

To avoid equipment damage and personal injury, never change handle position on control valve while pump is running.

### Before Disassembling Filter:

1. STOP PUMP.
  2. OPEN air release valve.
  3. WAIT until all pressure is released from filter tank and system before loosening clamp.
- ⚠ Releasing clamp with pressure on system will cause tank lid to blow off, causing severe injury or major property damage! NEVER adjust, tighten or loosen "V" band clamp when tank is under pressure!
  - ⚠ Properly seat filter clamp, torque clamp nut to 15 ft-lbs. and be sure gap between clamp ends is 3/8" or less before starting up filter (see Fig. 4).
  - ⚠ Do not operate filter at more than 50 PSI under any circumstances!

### Disassembly:

1. Backwash filter according to instructions under "Filter Backwash Procedure", (Page 8).
2. Stop pump.
3. Open air release valve (Key No. 1B, Page 12) on top of filter tank to release all air pressure from inside of tank and system.
4. Remove filter drain plug and drain all water from tank.
5. Loosen clamp nuts alternately until one is removed. Lift clamp assembly off of filter.
6. Being careful not to damage "O" ring (Key 7, Page 12), lift upper tank shell (Key No. 2, Page 12) off of lower tank shell (Key No. 11).

### Filling Filter with Sand:

1. Before pouring sand into filter, look inside and check internal assembly (Key No. 9, Page 12) for broken or loose laterals (Key No. 9A) caused by shipping damage. Replace if necessary.
2. To eliminate stress on laterals (Key No. 9A), fill tank half-full of water before loading sand.
3. See Table II for quantity of media required.
4. Fill until top of sand bed is 12½" below top of internal assembly. When full, top of sand bed should be about 12½" below top of distributor (about 1½" below flange—see Figure 1B).
5. Wash all sand and dirt away from "O" Ring sealing area.
6. Assemble filter according to instructions, Page 7.

## ⚠ WARNING

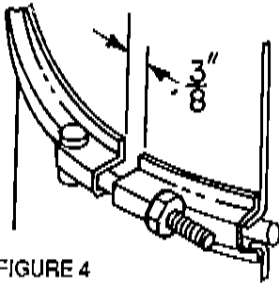

FIGURE 4

FIGURE 5

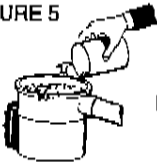

FIGURE 6



### Assembly:

1. Inspect "O" Ring (Key No. 7, Page 12) for cuts, nicks, etc. If damaged, replace with a new one.
2. Clean "O" Ring area of tank shell (both halves) and "O" Ring.
3. Carefully install "O" Ring and upper tank shell (Key No. 2, Page 12).  
 ⚠ Be sure upper tank shell contacts "O" Ring surface evenly and seal area is clean and free from dirt.  
 Be sure inside surface of clamp assembly is clean and free of dirt, etc.
4. Install clamp assembly and nuts. Tighten nuts evenly and alternately to keep the same gap between clamp halves on both sides of the filter. Tap clamp around tank with rubber hammer to assist sealing.  
 NOTICE: Final gap between clamp ends should be  $\frac{3}{8}$ " or less (see Fig. 4).  
 Torque clamp nuts to 15 foot-lbs. torque. Do not over-torque nuts.

### Startup (Multi-port Valve):

1. With pump OFF, set valve to 'BACKWASH' position.
2. Open air release valve (Key No. 1B, Page 12).
3. Start pump, circulating water backwards through filter to waste.
4. Close air release valve when a steady stream of water is expelled.
5. Run pump five minutes or until waste water is clear (this purges excess fine particles from system).
6. Stop pump; set valve handle to 'RINSE' position.
7. Start pump; run pump for one minute.
8. Stop pump; set valve to 'FILTER' position. Follow instructions under 'Regular Operation' (below) to place filter in service.

### Startup (Slide Valve):

1. With pump OFF, raise handle to fully extended position.
2. Open air release valve (Key No. 1B, Page 12).
3. Start pump, circulating water backwards through filter to waste.
4. Close air release valve when a steady stream of water is expelled.
5. Run pump five minutes or until waste water is clear (this purges excess fine particles from system).
6. Stop pump; lower handle completely to 'FILTER' position and pin in place. Follow instructions under 'Regular Operation' (below) to place filter in service.

## REGULAR OPERATION

### Run Filter:

1. With pump OFF, set valve to 'FILTER' position.
2. Fill trap on pump with water (Figure 5).
3. Open air release valve on top of filter assembly (Figure 6); start pump.
4. When steady stream of water comes from air release valve, close the valve.  
 ⚠ WARNING Close valve before air is drawn into system.
5. With filter operating, record pressure gauge reading in owner's manual. When reading is 10 PSI above initial reading, backwash filter according to instructions, Page 8.

**CAUTION****Backwash Filter (Multi-Port Valve):**

- ⚠** To prevent equipment damage and possible injury, turn pump OFF before changing valve position.
1. With pump OFF, set valve to 'BACKWASH' position.
  2. Open air release valve (Key No. 1B, Page 12).
  3. Start pump, circulating water backwards through filter to waste.
  4. Close air release valve when a steady stream of water is expelled.
  5. Backwash until water runs clear.
  6. Stop pump; set valve to 'RINSE' position.
  7. Start pump; run pump for one minute.
  8. Stop pump; set valve to 'FILTER' position.
  9. Filter is now ready for service.
  10. Open air release valve and release ALL pressure from system.
  11. Follow 'Run filter' procedure (Page 7) to restart system.

**Backwash Filter (Slide Valve):**

- ⚠** To prevent equipment damage and possible injury, turn pump OFF before changing valve position.
1. With pump OFF, raise valve handle to fully extended position.
  2. Open air release valve (Key No. 1B, Page 12).
  3. Start pump, circulating water backwards through filter to waste.
  4. Close air release valve when a steady stream of water is expelled.
  5. Backwash until water runs clear.
  6. Stop pump; lower handle completely to 'FILTER' position and pin in place.
  7. Filter is now ready for service.
  8. Open air release valve and release ALL pressure from tank and system.
  9. Follow 'Run filter' procedure (Page 7) to restart system.



## MAINTENANCE

### General:

- Wash outside of filter with a mild detergent and water. Rinse off with hose.
- **NOTICE:** DO NOT use solvents to clean filter; solvents may damage plastic components in system.
- Inspect sand bed at least once a year to remove foreign material which has not been backwashed out of system.
- **NOTICE:** When the sand bed gets hard and crusty on top, remove all the old sand and replace it with new sand.
- **NOTICE:** Open air bleed valve and bleed all air from filter each time pump is stopped and restarted.

### Weekly Inspection:

1. Skimmer basket - remove debris.
2. Stop pump, release all pressure. Remove trap cover and basket, remove debris.
3. Bleed air from filter each time system is started.
4. For systems with bypass valve, make sure separation tank is not under pressure.
5. Check pump for leaks. If found, see pump owner's manual.
6. Check pump strainer lid for tightness. **Do not over-tighten!**

### Monthly Inspections:

- ⚠ Release all pressure before adjusting clamp nuts.
  - ⚠ Releasing clamp with pressure on system will cause tank lid to blow off, causing severe injury or major property damage! NEVER adjust, tighten or loosen "V" band clamp when tank is under pressure!
1. Stop pump.
  2. Check "V" band clamp bolts and trap cover as follows:
    - ⚠ 1. STOP PUMP.
    2. OPEN air release valve.
    3. WAIT until all pressure is released from filter tank and system before adjusting clamp.
    4. Adjust nuts to proper torque (see below). Do not over-torque nuts.
  3. Adjust nuts to 15 foot-lbs. torque. Do not over torque nuts. Adjust nuts evenly and alternately to keep the same gap between clamp halves on both sides of the filter. Tap clamp around tank with rubber hammer to assist sealing.  
**NOTICE:** Final gap between clamp ends should be  $\frac{3}{8}$ " or less (see Fig. 7).
  4. Check gate valve packing glands. Tighten as necessary.
  5. Remove any standing water around base of pump as necessary.
  6. Start pump.

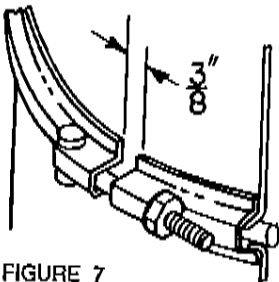
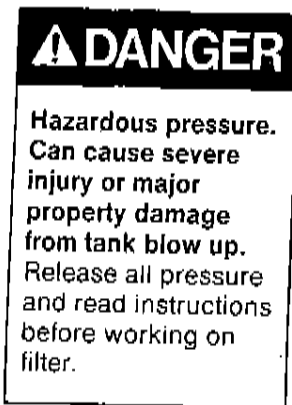

FIGURE 7

Figure 8A - Install four short laterals opposite inlet/outlet pipes (Models HRS20-01, HRS24-01 only).

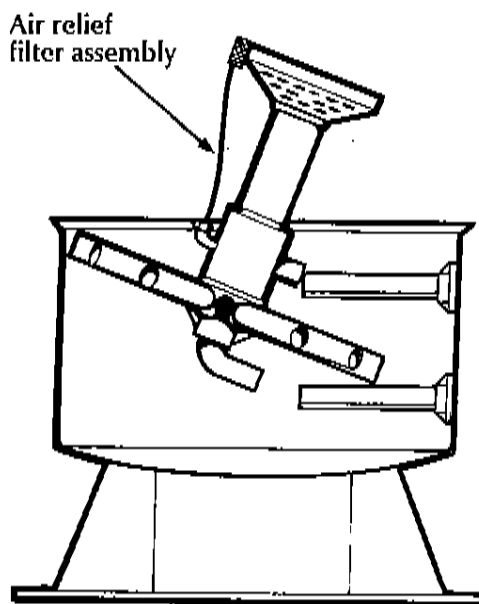
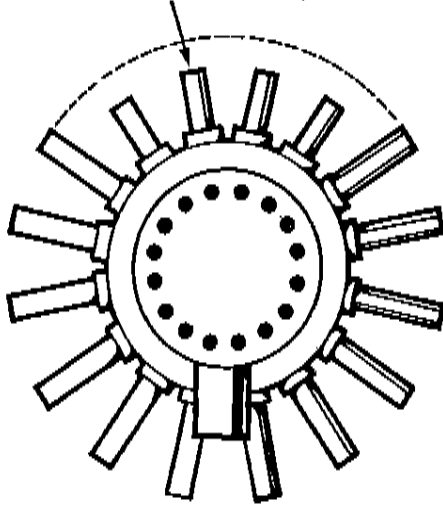

Figure 8B - Long laterals opposite inlet/outlet pipes will prevent installation of internal assembly.

### Replace Internal Assembly:

1. Disassemble filter according to instructions under "Filter Disassembly", Page 6.

**⚠WARNING** To avoid severe injury and major property damage, follow instructions on Pages 6 and 7 when disassembling and assembling filter.

2. Remove sand from filter.
3. Cut Tank Fitting Assemblies (Key No. 9E, Page 12) between tank nipple and center column. Remove Internal Assembly. Unscrew Tank Fitting Assemblies from Nipples.
4. Glue new laterals into hub in new center column. The four short laterals **MUST** be installed opposite inlet/outlet pipes (Models HRS20-01 and HRS24-01 only) or assembly will not fit into lower tank shell (see Figure 8A and 8B). Use Weldon 1707, 772, or similar ABS to ABS cement.

**⚠WARNING** To avoid serious personal injury or property damage, follow cement manufacturer's instructions exactly.

5. Thread new Tank Fitting Assemblies (Key No. 9E) into Nipples.
6. Move Air Relief Filter Assembly to new Internal Assembly.
7. Reinstall Internal Assembly in lower shell. Glue Tank Fitting Assemblies to Internal Assembly. Use Weldon 793 or similar ABS to PVC cement.

**⚠WARNING** To avoid serious personal injury or property damage, follow cement manufacturer's instructions exactly.

8. To refill, reassemble and restart filter, turn to "Filter Disassembly/Assembly", Pages 6 and 7.

**⚠WARNING** To avoid severe injury or major property damage, exactly follow "Assembly" instructions, Pages 6 and 7.

## WINTERIZING

1. Open air release valve; open all system valves. Position multiport valve between port positions to allow passage to all ports.
2. Remove drain plugs from trap, pump, valve, filter and separation tank.
3. Drain system piping.
4. Cover with plastic or tarpaulin to prevent water entrance and freezing.

## TROUBLESHOOTING GUIDE

### 1. Short Cycle between backwashes:

**NOTICE:** Time between backwashes will vary with each installation and between different areas of the country. The following causes and remedies are for cycle times shorter than normal for your area.

- A. Flow rate too high or filter too small; consult dealer for system sizing recommendations.
- B. Water is chemically out of balance; consult pool service man.
- C. Excess dirt/dust in pool; improve pool environment.
- D. Body oil/lotion build-up in filter; consult dealer for chemical filter cleaners and follow cleaner manufacturer's instructions.

**⚠** If cleaning agent requires disassembly of filter, exactly follow 'Disassembly'/'Assembly' instructions on Pages 6-7 of this manual to avoid severe personal injury and major property damage!

### 2. Low Flow/High Pressure:

- A. Pipe blocked downstream from filter; remove obstruction.
- B. Piping too small; use larger pipe (consult dealer for sizing).
- C. Filter area too small; consult dealer for recommendation.

### 3. Low Flow/Low Pressure:

- A. Pump too small; consult dealer for recommendations.
- B. Plugged pump or plugged hair and lint trap; clean thoroughly.

### 4. Pool Water Not Clear

- A. Water is chemically out of balance; consult pool service man.
- B. Inadequate turnover rate; consult dealer about equipment sizing.
- C. Sand in pool means broken lateral (Key No. 9A, Page 12):

**⚠** To avoid severe injury or major property damage, exactly follow instructions under "Disassembly" (Page 6) and "Assembly" (pages 6-7)!

1. Follow filter disassembly procedure, Page 6.
2. Replace lateral according to instructions supplied with new lateral, (see Figure 9, Page 13).
3. Reassemble filter according to instructions, Page 6.

### **⚠ DANGER**

**Hazardous pressure.  
Can cause severe  
injury or major  
property damage  
from tank blow up.  
Release all pressure  
and read instructions  
before working on  
filter.**

# MODELS

HRS16-01

HRS20-01

HRS24-01

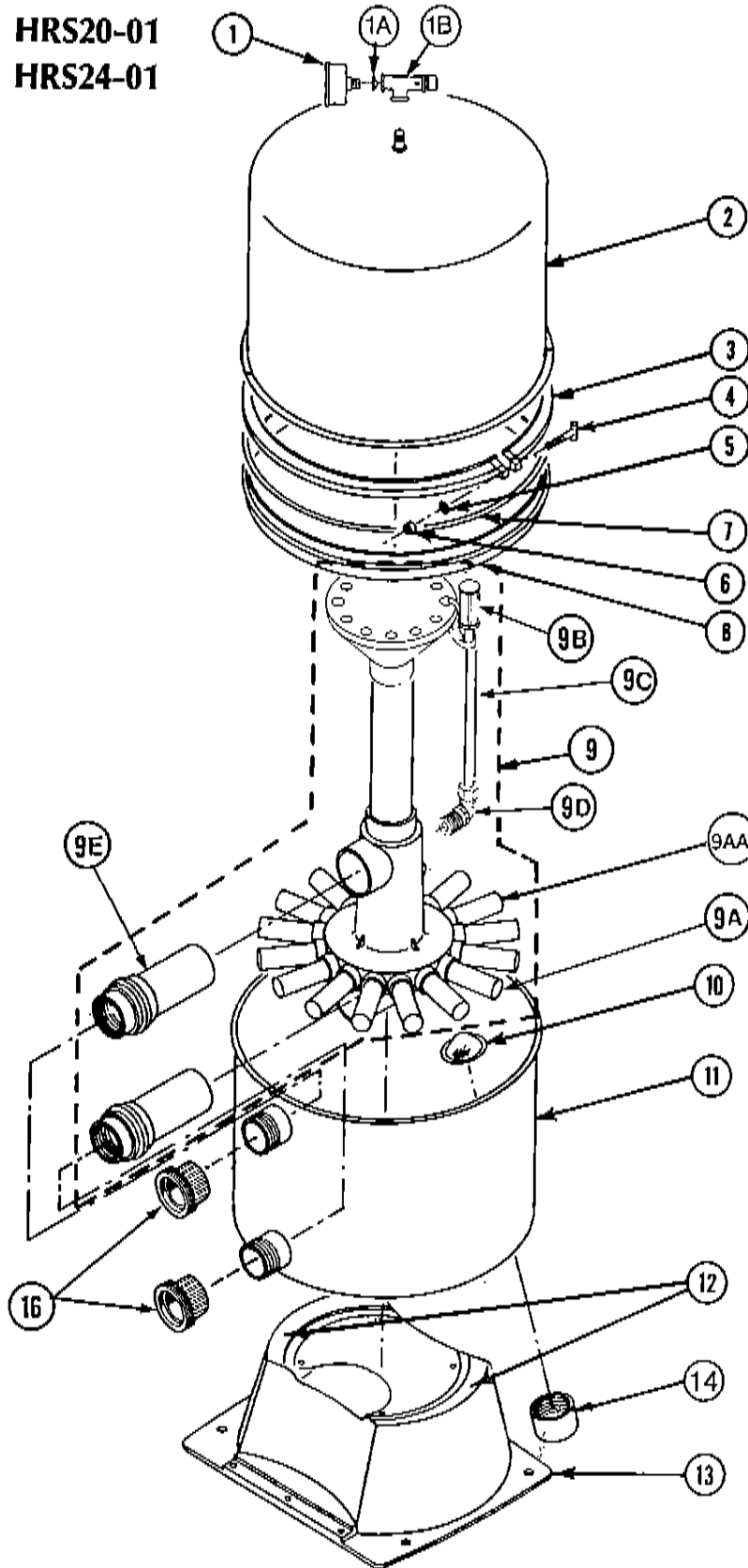

Your Filter uses the following safety and operating labels:

Model and Instruction Label:  
 WC33-78A (HRS16-01)  
 WC33-78B (HRS20-01)  
 WC33-78C (HRS24-01)

WC27-23 "WARNING - Turn off pump and open valve"

WC27-19 "CAUTION: Do not tighten or loosen clamp . . ."

60000-0137 Inlet-Outlet Label

Keep labels clean and in good condition. Replace damaged labels.

Install four short laterals opposite inlet/outlet pipes (Models HRS20-01, HRS24-01 only).

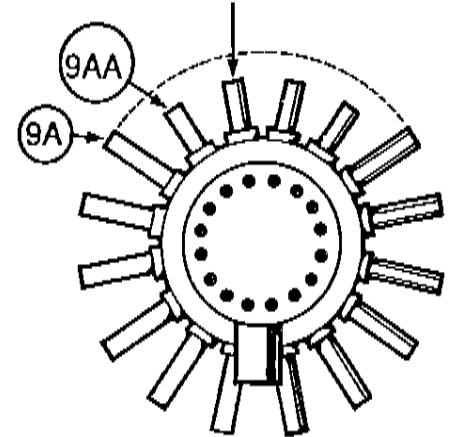

**WARNING** To avoid serious personal injury or property damage, follow cement manufacturer's instructions exactly.

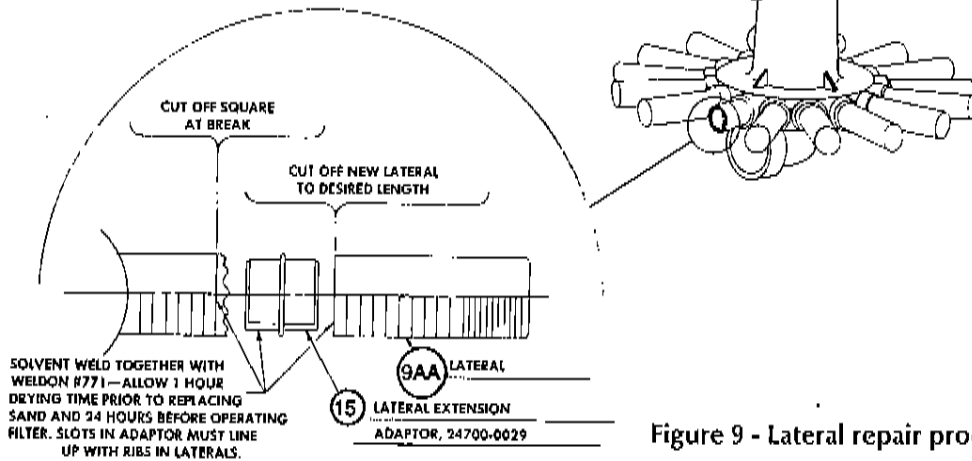

Figure 9 - Lateral repair procedure.

### REPAIR PARTS LIST

Key No.	Part Description	No. Used	Model HRS16-01	Model HRS20-01	Model HRS24-01
1	Pressure Gauge	1	33600-0023	33600-0023	33600-0023
1A	Screen	1	WC8-72D	WC8-72D	WC8-72D
1B	Air Release Valve	1	WC212-120P	WC212-120P	WC212-120P
2	Upper Shell	1	24735-0032A	23900-0324A	23901-0303A
3	Clamp	2	24700-0573	24700-0591	24700-0611
4	"T" Bolt - 5/16"	2	30767-0003	30767-0003	30767-0003
5	Washer - 5/16"	2	38907-0062	38907-0062	38907-0062
6	Hex Nut - 5/16 - 18	2	35402-0279	35402-0279	35402-0279
7	"O" Ring	1	24700-0068	24700-0072	24700-0073
8	Retaining Ring	1	24700-0063	24700-0065	24700-0067
9	Internal Assembly	1	24735-0001	24730-0001	24731-0001
9A	Lateral	( )	24735-0011(16)	24600-0003(12)	24700-0075(12)
9AA	Lateral, Short	4	—	24735-0011	24600-0375
9B	Air Bleed Filter	1	WC8-126	WC8-126	WC8-126
9C	Tube	1	WC37-384P	WC37-384P	WC37-384P
9D	Compression Elbow	1	WC78-84P	WC78-84P	WC78-84P
9E	Tank Fitting Assembly	2	24735-0015	24730-0015	24731-0015
10	Screen - Drain	1	23900-0046	23900-0046	23900-0046
*11	Lower Shell	1	24735-0005	23900-0023	23901-0023
12	Tape	2	37685-0006	37685-0006	37685-0006
13	Base	1	23910-0005	23900-0105	23901-0005
14	Pipe Cap	1	31285-4081	31285-4081	31285-4081
**15	Lateral Extension Adapter	As Req.	24700-0029	24700-0029	24700-0029
16	Union Adapter Assembly	2	U111-208P	U111-208P	U11-198P

\* When ordering item #11 for service, include label #60000-0137 and tape #37685-0006.

\*\* Available for lateral repairs, see Page 13, Figure 9.

