

STA-RITE®

MAX-E-GLAS II™ and DURA-GLAS II™ CENTRIFUGAL PUMPS WITH INTEGRAL TRAP O W N E R ' S M A N U A L

INSTALLATION, OPERATION & PARTS

Series P4E, P4EA, P4R, and P4RA
See Page 2 for Model Numbers

This manual should be furnished to the end user of this pump; its use will reduce service calls and chance of injury and will lengthen pump life.

© 2010 Pentair Water Pool and Spa, Inc. All rights reserved.

1620 Hawkins Ave., Sanford, NC 27330 • (919) 566-8000

10951 West Los Angeles Ave., Moorpark, CA 93021 • (805) 553-5000

Customer Support: (800) 831-7133

Sta-Rite®, Max-E-Glas™, Dua-Glas™ and Pentair Water Pool and Spa® is a trademark and/or registered trademark of Pentair Water Pool and Spa, Inc. and/or its affiliated companies in the United States and/or other countries. Plasto-Joint Stik® is a registered trademark of La-Co Industries, Inc. Teflon® is a registered trademark of E.I. Du Pont De Nemours and Company Corporation. Unless noted, names and brands of others that may be used in this document are not used to indicate an affiliation or endorsement between the proprietors of these names and brands and Pentair Water Pool and Spa, Inc. Those names and brands may be the trademarks or registered trademarks of those parties or others.

04-15-10

S454 (Rev. A)

'P4R' and 'P4E' SERIES II PUMP WITH TRAP

To avoid unneeded service calls, prevent possible injuries, and get the most out of your pump, READ THIS MANUAL CAREFULLY!

The Sta-Rite 'P4R' and 'P4E' Series II Self-priming Centrifugal pumps:

- Are designed for use with swimming pools or as centrifugal pumps.
- Are excellent performers; durable, reliable.

Table of Contents

Safety Instructions	2-3
Installation	3-5
Electrical	5-7
Operation	8-9
Storage/Winterizing	9
Pump Service	9-10
Troubleshooting Guide	11
Repair Parts List	12-16
Warranty	19

READ AND FOLLOW SAFETY INSTRUCTIONS!

 This is the safety alert symbol. When you see this symbol on your system or in this manual, look for one of the following signal words and be alert to the potential for personal injury.

▲ DANGER warns about hazards that will cause death, serious personal injury, or major property damage if ignored.

▲ WARNING warns about hazards that can cause death, serious personal injury, or major property damage if ignored.

▲ CAUTION warns about hazards that will or can cause minor personal injury or property damage if ignored.

NOTICE indicates special instructions not related to hazards.

Carefully read and follow all safety instructions in this manual and on equipment. Keep safety labels in good condition; replace if missing or damaged.

Max-E-Glas II™					
HP					
3/4	P4E6D-186L		P4E62D-186L	P4E6D-186LV	
1	P4E6E-187L	P4EA6E-186L	P4E62E-187L	P4E6E-187LV	
1-1/2	P4E6F-188L	P4EA6F-187L	P4E62F-188L	P4E6F-188LV	
1-3/4		P4EAA6F-198L			
2	P4E6G-189L	P4EA6G-188L	P4E62G-189L	P4E6G36-189	P4E6SSG36-189
2				P4E6G-189LV	P4EA6G-188LV
2-1/2		P4EAA6G-189L			
3				P4E6H-190LV	
3	P4E6H-190L		P4E62H-190L	P4E6H36-190	P4E6SSH36-190
Dura-Glas II™					
HP					
3/4	P4R62D3-186				P4R6D3-186
1	P4R62E3-187	P4R6E-187L	P4RA6E-186L		P4R6E3-187
1-1/2	P4R62F3-188	P4R6F-188L	P4RA6F-187L	P4RA6YF-187L	P4R6F3-188
1-3/4			P4RAA6F-198L		
2	P4R62G3-189	P4R6G-189L	P4RA6G-188L		P4R6G3-189
2-1/2			P4RAA6G-189L	P4RA6YG-188L	
3					P4R6H3-190

▲ WARNING
Hazardous pressure

Incorrectly installed or tested equipment may fail, causing severe injury or property damage. Read and follow instructions in owner's manual when installing and operating equipment. Have a trained pool professional perform all pressure tests.

1. Do not connect system to a high pressure or city water system.
2. Use equipment only in a pool or spa installation.
3. Install pump with at least 2 hydraulically balanced main drains equipped with correctly installed, screw-fastened, anti-entrapment certified covers. See Page 4.
4. Trapped air in system can cause explosion. **BE SURE** all air is out of system before operating or testing equipment.

Before pressure testing, make the following safety checks:

- Check all clamps, bolts, lids, and system accessories before testing.
- Release all air in system before testing.
- Tighten Sta-Rite trap lids to 30 ft. lbs. (4.1 kg-m) torque for testing.
- Water pressure for test must be less than 25 PSI (7.5 kg/cm²).
- Water Temperature for test must be less than 100° F (38° C).

IMPORTANT SAFETY INSTRUCTIONS

Always follow basic safety precautions with this equipment, including the following.

▲ WARNING To reduce the risk of injury, do not permit children to use this product unless they are closely supervised at all times.

▲ CAUTION This pump is for use with permanently installed pools and may also be used with hot tubs and spas if so marked. Do not use with storable pools. A permanently installed pool is constructed in or on the ground or in a building such that it cannot be readily disassembled for storage. A storable pool is constructed so that it may be readily disassembled for storage and reassembled to its original integrity.

SAVE THESE INSTRUCTIONS

- Limit test to 24 hours. After test, visually check system to be sure it is ready for operation. Remove trap lid and retighten hand tight only.

NOTICE: These parameters apply to Sta-Rite equipment only. For non-Sta-Rite equipment, consult manufacturer.

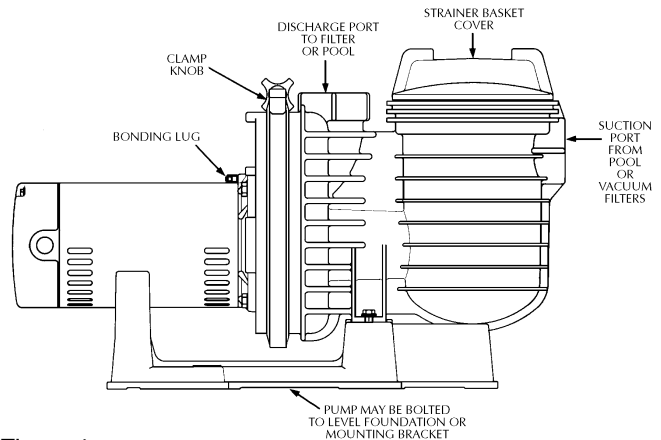

Figure 1

INSTALLATION

Only qualified, licensed personnel should install pump and wiring.

Pump mount must:

Be located away from corrosive or flammable chemicals.

Have enough ventilation to maintain air temperature at less than the maximum ambient temperature rating (Max. Amb.) listed on the motor model plate. If this pump is installed in an enclosure/pump house, the enclosure must have adequate ventilation and air circulation to keep the temperature in the enclosure at or below the motor's rated ambient temperature whenever the pump is running.

Be solid - Level - Rigid - Vibration free - Non-combustible. (To reduce vibration and pipe stress, bolt pump to mount.)

Allow pump suction inlet height to be as close to water level as possible.

Allow use of short, direct suction pipe (To reduce friction losses).

Allow for gate valves in suction and discharge piping.

Have adequate floor drainage to prevent flooding.

Be protected from excess moisture.

Allow adequate access for servicing pump and piping.

▲ WARNING Fire and burn hazard. Modern motors run at high temperatures. To reduce the risk of fire, do not allow leaves, debris, or foreign matter to collect around the pump motor. To avoid burns when handling the motor, let it cool for 20 minutes before trying to work on it.

NOTICE: Use Teflon tape or Plasto-Joint Stik for making all threaded connections to the pump. Do not use pipe dope; pipe dope will cause stress cracking in the pump.

NOTICE: Pump suction and discharge connections have molded in thread stops. DO NOT try to screw pipe in beyond these stops.

Teflon Taping Instructions:

Use only new or clean PVC pipe fittings.

Wrap male pipe threads with one to two layers of Teflon tape. Cover entire threaded portion of pipe.

Do not overtighten or tighten past thread stop in pump port!

If leaks occur, remove pipe, clean off old tape, rewrap with one to two additional layers of tape and remake the connection.

NOTICE: Support all piping connected with pump!

Piping:

Use at least 2" IPS PVC (51mm) pipe. Increase size if a long run is needed.

To avoid strains on the pump, support both suction and discharge pipes independently. Place these supports near the pump.

To avoid a strain left by a gap at the last connection, start all piping at the pump and run pipe away from the pump.

Never use a suction pipe smaller than pump suction connection.

To avoid airlocking, slope suction pipe slightly upward toward the pump.

NOTICE: To prevent flooding when removing pump for service, all flooded suction systems must have gate valves in suction and discharge pipes.

Fittings:

Fittings restrict flow; for best efficiency use fewest possible fittings.

Avoid fittings which could cause an air trap.

Pool fittings must conform to International Association of Plumbing and Mechanical Officials (IAPMO) standards.

Use only non-entrapping suction fitting or double suction.

POOL PUMP SUCTION REQUIREMENTS

▲ WARNING Pump suction is hazardous and can trap and drown or dismember bathers. Do not use or operate swimming pools, spas, or hot tubs if a suction outlet cover is missing, broken, or loose. Follow the guidelines below for a pump installation which minimizes risk to users of pools, spas, and hot tubs.

Entrapment Protection

The pump suction system must provide protection against the hazard of suction entrapment or hair entrapment/entanglement.

Suction Outlet Covers

All suction outlet covers must be maintained. They must be replaced if cracked, broken, or missing.

See below for outlet cover certification requirements.

All suction outlets must have correctly installed, screw-fastened covers in place.

Testing and Certification

Suction outlet covers must have been tested by a nationally recognized testing laboratory and found to comply with the latest ASME/ANSI Specification for Suction Fittings For Use in Swimming Pools, Spas, Hot Tubs, and Whirlpool Bathtub Applications.

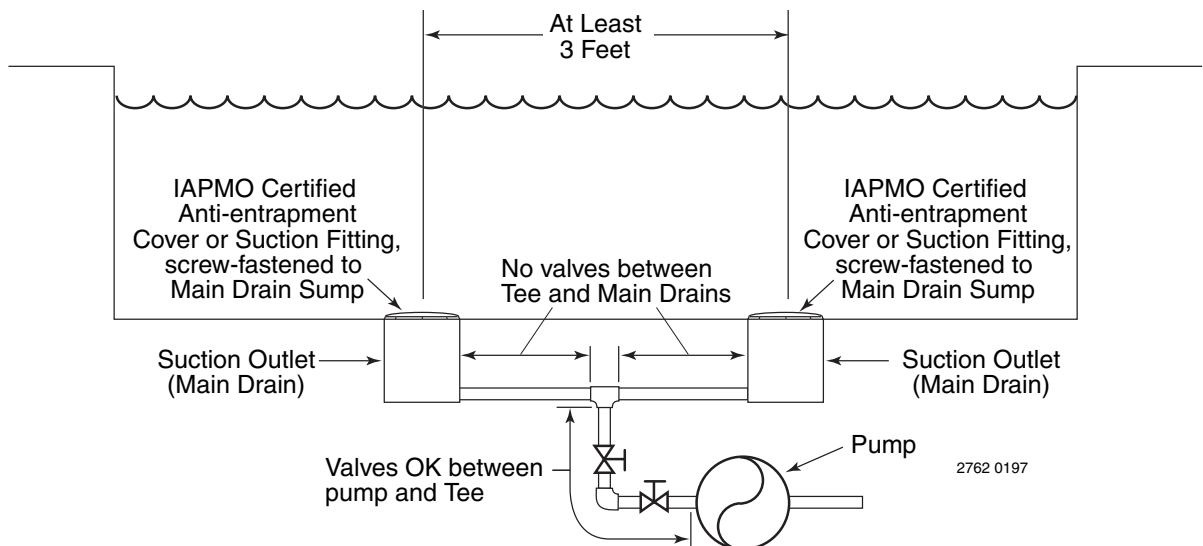

Figure 2 – Recommended pump suction layout.

Outlets Per Pump

Provide at least two hydraulically balanced main drains, with covers (see Page 4), for each swimming pool pump suction line. The centers of the main drains (suction fittings) must be at least three feet apart. The system must be built so that it cannot operate with the pump drawing water from only one main drain (that is, there must be at least two main drains connected to the pump whenever it is running). (See Figure 2). However, if two main drains run into a single suction line, the single suction line may be equipped with a valve which will shutoff both main drains from the pump (see Figure 2). More than one pump can be connected to a single suction line as long as the requirements above are met.

Water Velocity

The maximum water velocity through any suction outlet must be 1.5 feet per second unless the outlet complies with the latest ASME/SNSI Specification for Suction Fittings For Use in Swimming Pools, Spas, Hot Tubs, and Whirlpool Bathtub Applications. In any case, do not exceed the suction fittings maximum designed flow rate. If 100% of the pump's flow comes from the main drain system, the maximum water velocity in the pump suction hydraulic system must be six feet per second or less even if one main drain (suction fitting) is completely blocked. The flow through the remaining main drain(s) must comply with the latest ASME/ANSI Specification

for Suction Fittings For Use in Swimming Pools, Spas, Hot Tubs, and Whirlpool Bathtub Applications.

⚠ WARNING



Hazardous voltage. Can shock, burn, or cause death.

Ground pump before connecting to power supply.

ELECTRICAL

- ⚠ Ground motor before connecting to electrical power supply. Failure to ground motor can cause severe or fatal electrical shock hazard.
- ⚠ Do not ground to a gas supply line.
- ⚠ To avoid dangerous or fatal electrical shock, turn OFF power to motor before working on electrical

connections.

⚠ Ground Fault Circuit Interrupter (GFCI) tripping indicates an electrical problem. If GFCI trips and will not reset, have a qualified electrician inspect and repair electrical system.

⚠ Exactly match supply voltage to nameplate voltage. Incorrect voltage can cause fire or seriously damage motor and voids warranty. If in doubt consult a licensed electrician.

Voltage

Voltage at motor must be not more than 10% above or below motor nameplate rated voltage or motor may overheat, causing overload tripping and reduced component life. If voltage is less than 90% or more than 110% of rated voltage when motor is running at full load, consult power company.

Grounding/Bonding

Install, ground, bond and wire motor according to local or National Electrical Code requirements.

Permanently ground motor. Use green ground terminal provided under motor canopy or access plate (See Figure 3); use size and type wire required by code. Connect motor ground terminal to electrical service ground.

Bond motor to pool structure. Use a solid copper conductor, size No. 8 AWG (8.4 sq.mm) or larger. Run wire from external bonding lug (see Figure 3) to reinforcing rod or mesh.

Connect a No. 8 AWG (8.4 sq.mm) solid copper bonding wire to the pressure wire connector provided on the motor housing and to all metal parts of the

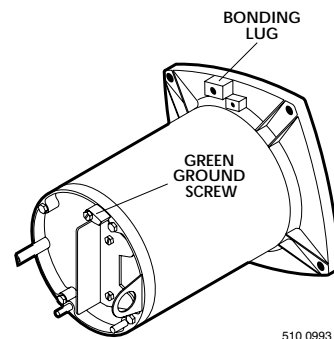

Figure 3: Typical ground screw and bonding lug locations.

swimming pool, spa, or hot tub and to all electrical equipment, metal piping or conduit within 5 feet (1.5 m) of the inside walls of swimming pool, spa, or hot tub.

Wiring

NOTICE: 3 phase models require magnetic motor starters and external overload protection. If in doubt about the procedure, consult a licensed electrician.

Pump must be permanently connected to circuit. See Figures 4A, 4B, and 4C for wiring connection diagrams. Match wire and circuit breaker sizes to correct Fusing and Wiring Data Chart (Page 7). If other lights or appliances are also on the same circuit, be sure to add their amp loads to pump amp load. (If unsure how to do this or if this is confusing, consult a licensed electrician.) Use the load circuit breaker as the master on-off switch.

Install a Ground Fault Circuit Interrupter (GFCI) in circuit; it will sense a short-circuit to ground and disconnect power before it becomes dangerous to pool users. For size of GFCI required and test procedures for GFCI, see manufacturer's instructions.

In case of power outage, check GFCI for tripping (which will prevent normal water circulation). Reset if necessary.

NOTICE: If you do not use conduit when wiring motor, be sure to seal wire opening on end of motor to prevent dirt, bugs, etc., from entering motor.

⚠ WARNING Risk of dangerous or fatal electrical shock.

Be sure that power to the motor circuit is off before working on wiring, wiring connections, or motor. Re-install the motor end cover and all other wiring covers before turning on the power.

1. Turn off power.
2. Remove the motor end cover.

To Wire a Single Speed, Single Voltage Motor

There are two terminals labeled L1 and L2. Attach the power leads to these terminals. Either wire may attach to either terminal.

To Wire a Dual-Voltage Motor

Dual voltage motors have a plug to change from 230 volts (factory setting) to 115 volts.

1. If you have 230 volts motor supply voltage, confirm that the plug is set for 230 volts. The arrow on the plug will point to the 230 volt position. Note that plug only connects with one prong in this position.
2. If you have 115 volt supply, pull the plug straight up and place it on the two brass prongs as shown.

NOTE: Arrow is highlighted for clarity.

To Wire a Two-Speed Motor

Wire the pump as shown in the diagram.

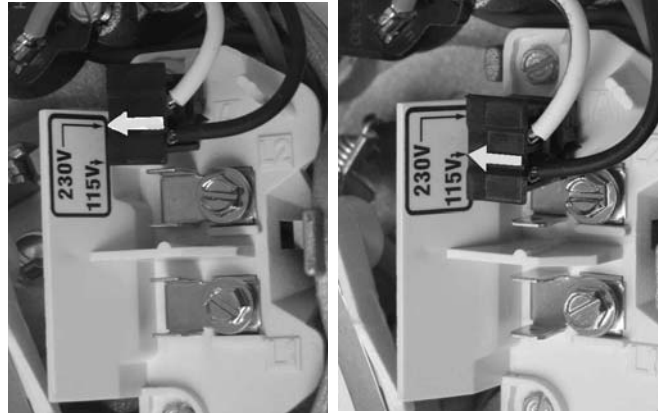
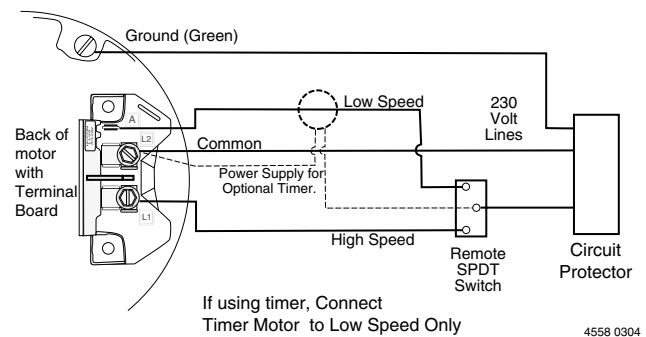

Figure 4A -Voltage Change Plug Set for 230 Volts

Figure 4B Voltage Change Plug Set for 115 Volts



Minimum switch and timer amp rating must equal Branch Fuse Rating given in "Recommended Fusing and Wiring Data" table.

Figure 4C: 2-Speed Motor Wiring Diagram

TABLE I - RECOMMENDED FUSING AND WIRING DATA – P4E, P4EA MODELS

Motor HP	Branch Fuse Rating Amps*	Max Load Amps	Voltage/ Hz/Phase	Serv. to Motor - Dist. in Ft. (M)			Wire Size AWG (mm ²)
				0-100' (0-30 M)	101-200' (30-60 M)	201-300' (60-90 M)	
P4E Models:							
3/4	20	13.8	115/60/1	12(3)	10(5.5)	8(8.4)	}
1	25	16.0	115/60/1	12(3)	8(8.4)	6(14)	
1	15	8.0	230/60/1	14(2)	14(2)	14(2)	
1-1/2	15	10.4	230/60/1	14(2)	12(3)	12(3)	
2	15	11.2	230/60/1	14(2)	12(3)	12(3)	
2	15	1.5	575/60/3	14(2)	14(2)	14(2)	
3	15	3.4	575/60/3	14(2)	14(2)	14(2)	
3	25	15.8	230/60/1	12(3)	12(3)	10(5.5)	
P4EA Models:							
1	20	13.8	115/60/1	12(3)	10(5.5)	8(8.4)	}
1-1/2	25	16.0	115/60/1	12(3)	8(8.4)	6(14)	
1	15	6.9	230/60/1	14(2)	14(2)	14(2)	
1-1/2	15	8.0	230/60/1	14(2)	14(2)	12(3)	
1-3/4	15	10.4	230/60/1	14(2)	12(3)	12(3)	
2	15	10.4	230/60/1	14(2)	12(3)	12(3)	
2-1/2	15	11.2	230/60/1	14(2)	12(3)	12(3)	
P4E62 Models:							
3/4	20	13.4	100/60/1	14(2)	12(3)	8(8.4)	}
3/4	15	6.7	200/60/1	14(2)	14(2)	14(2)	
1	15	7.4	200/60/1	14(2)	14(2)	12(3)	
1-1/2	15	10.5	200/60/1	14(2)	12(3)	12(3)	
2	20	14.2	200/60/1	12(3)	12(3)	10(5.5)	
3	25	17.6	200/60/1	10(5.5)	10(5.5)	10(5.5)	

* Time delay fuses are recommended instead of standard fuses in any motor circuit.

TABLE II - RECOMMENDED FUSING AND WIRING DATA – P4R, P4RA MODELS

Motor HP	Branch Fuse Rating Amps*	Max Load Amps	Voltage/ Hz/Phase	Serv. to Motor - Dist. in Ft. (M)			Wire Size AWG (mm ²)
				0-100' (0-30 M)	101-200' (30-60 M)	201-300' (60-90 M)	
P4R Models:							
1	30	19.2	115/60/1	10(5.5)	8(8.4)	6(14)	}
1	15	9.6	230/60/1	14(2)	14(2)	12(3)	
1-1/2	15	12.0	230/60/1	14(2)	14(2)	12(3)	
2	15	11.2	230/60/1	14(2)	14(2)	12(3)	
P4RA Models:							
1	20/15	15.3/7.6	115/230/60/1	12/14(3/2)	8/14(8.4/2)	6/14(14/2)	}
1-1/2	30	19.2	115/60/1	10(5.5)	8(8.4)	6(14)	
1-1/2	15	9.6	230/60/1	14(2)	14(2)	12(3)	
1-3/4	15	12.0	230/60/1	14(2)	14(2)	12(3)	
2	15	12.0	230/60/1	14(2)	14(2)	12(3)	
2-1/2	15	11.2	230/60/1	14(2)	14(2)	12(3)	
P4RA 2-Speed Models:							
1-1/2 - 1/4	15	9.2/2.5	230/60/1	14(2)	14(2)	12(3)	}
2 - 1/3	15	10.2/3.7	230/60/1	14(2)	14(2)	12(3)	
P4R62 Models:							
3/4	15	3.8	200/60/3	14(2)	14(2)	14(2)	}
1	15	5.6	200/60/3	14(2)	14(2)	14(2)	
1-1/2	15	6.6	200/60/3	14(2)	14(2)	14(2)	
2	15	9.8	200/60/3	14(2)	14(2)	14(2)	
P4R6 3-Phase Models:							
3/4	15/15	3.6/1.8	230/460/60/3	14(2)	14(2)	14(2)	}
1	15/15	4.7/2.35	230/460/60/3	14(2)	14(2)	14(2)	
1-1/2	15/15	5.8/2.9	230/460/60/3	14(2)	14(2)	14(2)	
2	15/15	7.0/3.5	230/460/60/3	14(2)	14(2)	14(2)	
2-1/2	15/15	9.7/4.9	230/460/60/3	14(2)	14(2)	12(3)/14(2)	
3	15/15	11.5/5.8	230/460/60/3	14(2)	14(2)	12(3)/14(2)	

* Time delay fuses are recommended instead of standard fuses in any motor circuit.

OPERATION

⚠ NEVER run pump dry. Running pump dry may damage seals, causing leakage and flooding. Fill pump with water before starting motor.

⚠ CAUTION Before removing trap cover:

1. STOP PUMP before proceeding.
2. CLOSE GATE VALVES in suction and discharge pipes.
3. RELEASE ALL PRESSURE from pump and piping system.
4. NEVER tighten or loosen clamp while pump is operating!



⚠ If pump is being pressure tested, be sure pressure has been released before removing trap cover.

⚠ Do not block pump suction. To do so with body may cause severe or fatal injury. Small children using pool must ALWAYS have close adult supervision.

⚠ WARNING Fire and burn hazard. Modern motors run at high temperatures. To reduce the risk of fire, do not allow leaves, debris, or foreign matter to collect

around the pump motor. To avoid burns when handling the motor, let it cool for 20 minutes before trying to work on it. An automatic internal cutoff switch protects the motor from heat damage during operation.

NOTICE: Maximum ambient temperature for motor operation must not exceed maximum ambient temperature rating on motor model plate.

Priming Pump

Release all pressure from filter, pump, and piping system; see the filter owner's manual.

In a flooded suction system (water source higher than pump), pump will prime itself when suction and discharge valves are opened.

If pump is not in a flooded suction system, unscrew and remove trap cover; fill trap and pump with water.

Do not lubricate the trap cover O-Ring. The original equipment O-Ring contains a permanent internal lubricant.

NOTICE: If you replace the O-Ring with a non-internally lubricated O-Ring, you may need to apply a silicone based lubricant.

Clean and inspect O-Ring; reinstall on trap cover.

Replace trap cover on trap; turn clockwise to tighten cover.

NOTICE: Tighten trap cover by hand only (no wrenches)! Use a wrench only if necessary to remove lid!

Pump should prime now. Priming time will depend on vertical length of suction lift and horizontal length of suction piping.

If pump does not prime, make sure that all valves are open, suction pipe end is under water, and that there are no leaks in suction pipe. See Troubleshooting Guide, Page 11.

Routine Maintenance

The only routine maintenance needed is inspection/cleaning of trap basket. Debris or trash that collects in basket will choke off water flow through the pump. Follow instructions below to clean trap:

1. Stop pump, close valves in suction and discharge, and release all pressure from system before proceeding.
2. Unscrew trap lid (turn counterclockwise). If necessary, use a lever such as a board or long screwdriver between lugs on trap cover.
3. Remove strainer basket and clean. Be sure all holes in basket are clear, flush basket with water and replace in trap with large opening at pipe connection port (between ribs provided). If basket is replaced backwards cover will not fit on trap body.
4. Clean and inspect lid O-Ring; reinstall on trap cover.
5. Clean O-Ring groove on trap body and replace lid. To help keep lid from sticking, tighten hand tight only (no wrenches!).
6. Prime pump (see priming instructions).

Draining Pump



1. Pump down water level below all inlets to the pool.

⚠ To avoid dangerous or fatal electrical shock hazard, turn OFF power to motor before draining pump.

2. Remove trap cover and use low pressure air to blow accumulated water from the piping system. Lugs have been provided on the trap lid to use a lever or pry bar for loosening.
3. Cap inlet piping after draining to keep water out of the pipes.
4. To prevent pump from freezing, remove trap

cover and drain the tank body through the drain plugs (Key No. 19, Pages 12 - 16). Clean pump and trap basket thoroughly; replace trap cover.

NOTICE: Tighten trap cover by hand only (no wrenches)! Use a lever or wrench only if necessary to remove cover! If pump is not anchored, use caution not to break attached piping!

5. Be sure motor is kept dry and covered.

Storage/Winterizing:

⚠ WARNING Explosion hazard. Purging the system with compressed air can cause components to explode, with risk of severe injury or death to anyone nearby. Use only a low pressure (below 5 PSI), high volume blower when air purging the pump, filter, or piping.

NOTICE: Allowing pump to freeze will damage pump and void warranty!

NOTICE: Do not use anti-freeze solutions (except propylene glycol) in your pool/spa system. Propylene glycol is non-toxic and will not damage plastic system components; other anti-freezes are highly toxic and may damage plastic components in the system.

Drain all water from pump and piping when expecting freezing temperatures or when storing pump for a long time (see instructions below).

Keep motor dry and covered during storage.

To avoid condensation/corrosion problems, do not cover pump with plastic.

For outdoor/unprotected installations:

1. Gravity drain system as far as possible.
2. Protect areas which retain water with non-toxic propylene glycol antifreeze ("RV antifreeze").
3. Enclose entire system in a weatherproof enclosure.
4. To avoid condensation/corrosion damage, allow ventilation; do not wrap system in plastic.
5. Use a 40% propylene glycol/60% water solution to protect pump to -50°F (-46°C).

Startup For Winterized Equipment

1. Remove any temporary weather protection placed around system.
2. Follow filter manufacturer's instructions for reactivation of the filter.
3. Inspect all electrical wiring for damage or deterioration over the shutdown period. Have a qualified serviceman repair wiring as needed.
4. Inspect and tighten all watertight connections.
5. Open all valves in suction and return piping.
6. Remove any winterizing plugs in piping system.
7. Drain all antifreeze from system.
8. Close all drain valves and replace all drain plugs in piping system.
9. Prime pump according to instructions on Page 8.

PUMP SERVICE

Pump should only be serviced by qualified personnel.

For best results, use only genuine Sta-Rite factory parts.

Be sure to prime pump (Page 8) before starting.

⚠ CAUTION Before removing clamp or trap cover:

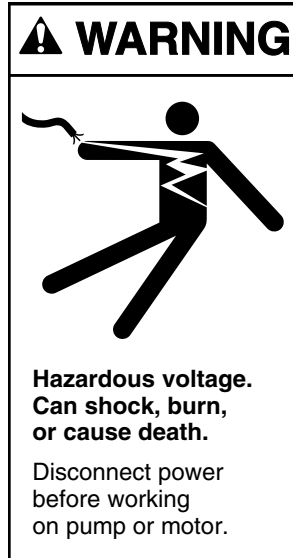

1. STOP PUMP before proceeding.
 2. CLOSE GATE VALVES insuction and discharge pipes.
 3. RELEASE ALL PRESSURE from pump and piping system.
 4. NEVER tighten or loosen clamp while pump is operating!
- ⚠** To avoid dangerous or fatal electrical shock hazard, turn OFF power to motor before working on pump or motor.

Aside from lubricating trap cover "O" Ring, no lubrication or regular maintenance is needed beyond reasonable care and periodic cleaning of strainer basket.

If shaft seal is worn or damaged, repair as follows:

Pump Disassembly/Removing Old Seal

Disconnect power to pump motor.

⚠ Be sure gate valves on suction and return piping are closed before starting work.

Release all pressure by opening all vents before starting work.

1. Drain pump by removing drain plugs on bottom of pump body and trap body.
2. Be sure there is no pressure in trap body; remove cover (unscrew by turning counterclockwise).
3. Remove clamp holding pump halves together. Motor and seal plate assembly can now be pulled away from pump body.
4. Remove five screws and washers holding diffuser to seal plate. Remove diffuser.
5. Remove motor canopy. Being careful not to touch capacitor terminals, loosen capacitor clamp and move capacitor to one side.
6. Hold shaft with 7/16" open-end wrench on motor shaft flats.

7. Unscrew impeller from shaft (turn counterclockwise when facing it).
NOTICE: On models with impeller screw: Remove impeller screw (left hand thread - turn clockwise) and gasket before removing impeller. Inspect gasket for damage, cracks, etc. Replace if damaged.
8. Pull rotating member of seal off of impeller sleeve; clean sleeve.
9. Remove four screws holding seal plate to motor.
10. Place seal plate face down on flat surface and tap out ceramic seat.
11. Clean seal cavity in seal plate and clean motor shaft.

Pump Reassembly/Installing New Seal

1. Ceramic seat must be clean and free of dirt, grease, dust, etc. Wet outer edge of rubber cup on ceramic seat with small amount of liquid detergent; press

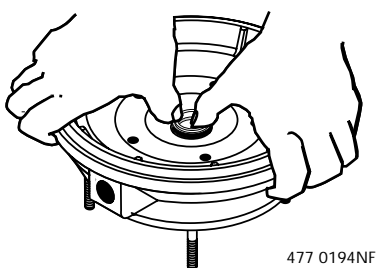

Figure 5: Press seal into heat sink in seal plate

ceramic seat into seal plate insert firmly and squarely with finger pressure (Figure 5).

2. If ceramic seat will not locate properly, remove it, place face up on bench and reclean cavity. Ceramic seat should now locate.
3. If seat still will not locate properly, place a

cardboard washer over the polished face and use a piece of 3/4" (19mm) standard pipe for pressing purposes. NOTICE: Be sure not to scratch or mar polished surface or seal will leak.

4. Remount seal plate on motor. Tighten bolts to 60-80 inch-lbs. (69-92 kg/cm) torque.
5. Apply a small amount of liquid detergent to inside diameter of rotating half of seal.
6. Slide rotating seal member, polished face last, over impeller sleeve until rubber drive ring hits shoulder.
NOTICE: Be sure not to nick or scratch polished seal face; seal will leak if face is damaged.
7. Screw impeller onto shaft (clockwise); this will automatically locate seal in seal plate.

NOTICE: On models with impeller screw: Install impeller gasket and lock screw (left-hand thread - turn counterclockwise). Torque lock screw to 50-55 inch-lbs. (57.6-63 kg/cm).

8. Mount diffuser on seal plate; tighten screws to 10-14 inch-lbs. (11.2-16.1 kg/cm) torque.
9. Assemble motor and seal plate to volute; be sure clamp is properly seated.

NOTICE: Clamp knob can be located in any position around volute; if it is moved after assembly, tighten knob while tapping around clamp to assist sealing. Do not move clamp while pump is full of water.

▲ WARNING Hazardous pressure. Release all pressure from pump and piping system before working on pump or attempting to adjust or remove clamp. Clamp may blow off of pump if adjusted under pressure.

10. Prime pump according to instructions on Page 8.

TROUBLESHOOTING GUIDE

 Read and understand safety and operating instructions in this manual before doing any work on pump!

 Only qualified personnel should electrically test pump motor!

FAILURE TO PUMP; REDUCED CAPACITY OR DISCHARGE PRESSURE

Suction leaks/lost prime:

1. Pump must be primed; make sure that pump volute and trap are full of water. See priming instructions, Page 8.
2. Make sure there are no leaks in suction piping.
3. Make sure suction pipe inlet is well below the water level to prevent pump from sucking air.
4. Suction lift of 10 to 20 feet (3-6 M) will reduce performance. Suction lift of more than 20 feet (6 M) will prevent pumping and cause pump to lose prime. In either case, move pump closer (vertically) to water source. Make sure suction pipe is large enough.

Clogged pipe/trap/impeller, worn impeller:

5. Make sure suction trap is not clogged; if it is, clean trap and strainer.
6. Make sure impeller is not clogged (follow steps 1 through 7 under "Removing Old Seal", Page 9; check impeller for clogging; follow steps 7 through 10 under "Installing New Seal", Page 10, for reassembly).
7. Impeller and diffuser may be worn. If so, order replacement parts from Repair Parts List, Pages 12-16.
8. Pump may be trying to push too high a column of water. If so, a "higher head" pump is needed.

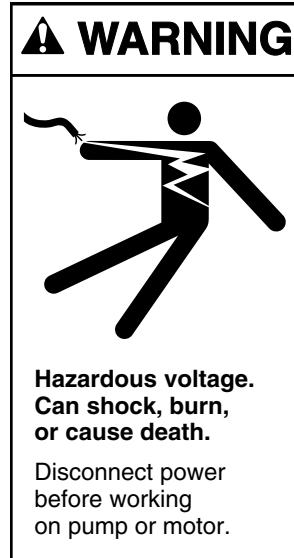

Electrical:

9. Pump may be running too slowly; check voltage at motor terminals and at meter while pump is running. If low, see wiring instructions or consult power company. Check for loose connections.
10. Pump may be too hot.
 - A. Check line voltage; if less than 90% or more than 110% of rated voltage consult a licensed electrician.
 - B. Increase ventilation.
 - C. Reduce ambient temperature.
 - D. Tighten any loose connections.

MECHANICAL TROUBLES AND NOISE

1. If suction and discharge piping are not adequately supported, pump assembly will be strained. See "Installation", Page 3.
2. Do not mount pump on a wooden platform! Securely mount on concrete platform for quietest performance.

P4E, P4EA and P4E62 SERIES
MAX-E-GLAS II POOL PUMP
3/4 through 3 HP Models

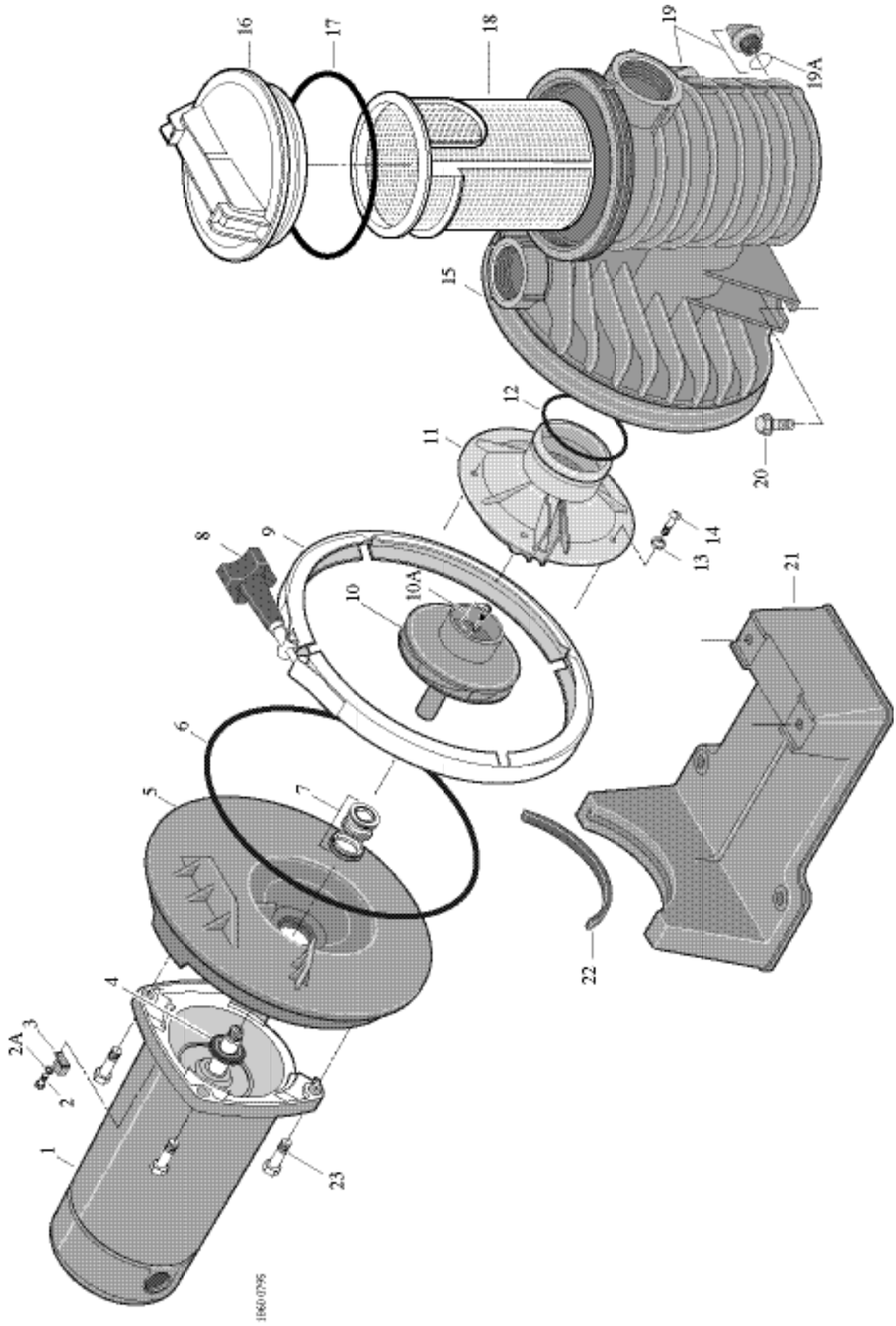

REPAIR PARTS LIST

Key No.	Part Description	Qty.	Part No.
1	Motor	1	Chart at Right
2	#10-32x1/2" Screw	1	U30-692SS
2A	Lock Washer	1	U43-22SS
3	Bonding Lug	1	U17-568
4	Water Slinger	1	17351-0009
5	Seal Plate Kit (Incl. Key Nos. 6, 7)#	1	C203-194P
6	O-Ring	1	U9-228A
7	Shaft Seal†	1	37400-0027S
8	Clamp Knob	1	C19-37A
9	Clamp	1	WC36-22
10	Impeller	1	Chart at Right
10A	Impeller Screw Assembly	1	17301-0151
11	Diffuser	1	Chart at Right
12	Diffuser O-Ring	1	U9-374
13	#8 Lock Washer	5	U43-21SS
14	Screw (w/C1-271P Diffuser)	5	U30-922SS
14	Screw (w/C1-271P1 Diffuser)	5	U30-542SS
15	Tank Body	1	C176-59P
16	Trap Cover	1	C3-185P
17	Trap O-Ring	1	U9-375
18	Basket	1	C8-58P
19	1/4" NPT Drain Plug	2	U178-920P
20	Base Screw	2	U30-918SS
21	Base w/Motor Pad**	1	C104-78P
22	Motor Pad	1	C35-43
23	3/8-16x1" Hex Hd. Screw	4	U30-74SS
•	Motor Nameplate	1	32155-7117
•	Tag, "CAUTION, WARNING (bonding)"		61002-0002
•	Decal, "Do not overtighten..."		U27-644
•	Nameplate (P4E Series)		32155-4035
•	Nameplate (P4EA Series)		32155-4071

• Not illustrated.

** Models P4E6H and P4E62H use Base No. C104-79P and Motor Pad No. C35-44.

Models P4E6SSG36-189 and P4E6SSH36-190 use Part No. C203-194SS.

† Models with "LV" suffix use Part No. 37400-0028S.

P4E, P4EA and P4E62 SERIES MAX-E-GLAS II POOL PUMP 3/4 through 3 HP Models

Models with "LV" suffix are identical to corresponding models with "L" suffix except for the shaft seal, which is Viton equipped.

Parts are common to all models listed except as noted; Key Nos. 1, Motor; 10, Impeller; and 11, Diffuser are listed below.

Model No.	HP	Motor No. (Key No. 1)	Impeller (Key No. 10)	Diffuser (Key No. 11)
115/230 Volt				
P4E6D-186L	3/4	AE100DHL	C105-238P	C1-271P1
P4E6E-187L	1	AE100EHL	C105-238PB	C1-271P1
P4EA6E-186L	1	AE100ELL	C105-238P	C1-271P1
P4EA6F-187L	1-1/2	AE100FLL	C105-238PB	C1-271P1
230 Volt				
P4E6F-188L*	1-1/2	AE100FHL	C105-238PDBA	C1-271P
P4EAA6F-198L*	1-3/4	AE100F5LL	C105-238PDCA	C1-271P
P4E6G-189L*	2	AE100GHL	C105-238PEBA	C1-271P
P4EA6G-188L*	2	AE100GLL	C105-238PDBA	C1-271P
P4EAA6G-189L*	2-1/2	AE100G5LL	C105-238PEBA	C1-271P
P4E6H-190L*	3	AE100HLL	C105-238PLA	C1-271P
100/200 Volt				
P4E62D-186L	3/4	AE100DH2	C105-238P	C1-271P1
200 Volt				
P4E62E-187L	1	AE100EH2	C105-238PB	C1-271P1
P4E62F-188L*	1-1/2	AE100FH2	C105-238PDBA	C1-271P
P4E62G-189L*	2	AE100GH2	C105-238PEBA	C1-271P
P4E62H-190L*	3	AE100GHL2	C105-238PLA	C1-271P
575 Volt				
P4E6G36-189*	2	62003-2087	C105-238PEBA	C1-271P
P4E6SSG36-189*	2	62003-2087	C105-238PEBA	C1-271PSS
P4E6H36-190*	3	62001-1021	C105-238PLA	C1-271P
P4E6SSH36-190*	3	62001-1021	C105-238PLA	C1-271PSS

*Uses Impeller Screw No. 37337-6080. See Repair Parts List.

P4R and P4RA SERIES DURA-GLAS II POOL PUMP 1 through 2-1/2 H.P. Models

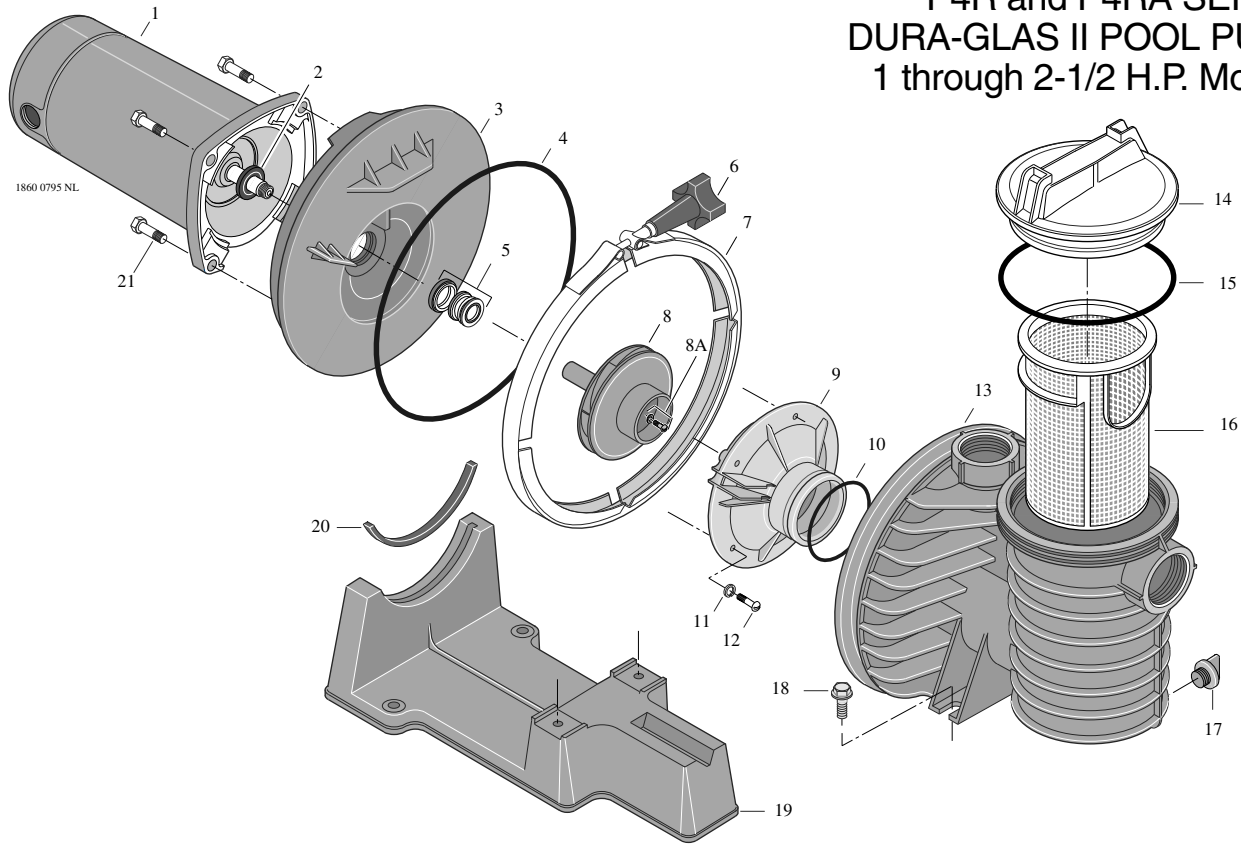

REPAIR PARTS LIST

Key No.	Part Description	Qty.	Part No.
1	Motor	1	Chart at Right
2	Water Slinger	1	17351-0009
3	Seal Plate (includes Key Nos. 4 and 5)	1	C203-194P
4	O-Ring	1	U9-228A
5	Shaft Seal	1	37400-0027S
6	Clamp Knob	1	C19-37A
7	Clamp	1	WC36-22
8	Impeller	1	Chart at Right
8A	Impeller Screw Assembly	1	17301-0151
9	Diffuser*	1	C1-271P1
10	Diffuser O-Ring	1	U9-374
11	#8 Lock Washer	5	U43-21SS
12	Screw**	5	U30-922SS
13	Tank Body	1	C176-59P
14	Trap Cover	1	C3-185P
15	Trap O-Ring	1	U9-375
16	Basket	1	C8-58P
17	1/4" NPT Drain Plug	2	U178-920P
18	Base Screw	2	U30-918SS
19	Base w/Motor Pad	1	C104-78P
20	Motor Pad	1	C35-43
21	3/8-16 x 1" Hex Head Screw	4	U30-74SS
	• Decal "Suitable for outdoor use . . ."		U27-635
	• Motor Nameplate	1	32155-7117
	• Tag, "CAUTION"		61002-0002
	• Tag, "CAUTION, WARNING (Bonding)"		C63-12
	• Nameplate***		U33-174

Parts are common to all models listed except as noted; Key Nos. 1, Motor; and 10, Impeller are listed below.

Model No.	HP	Motor No. (Key No. 1)	Impeller No. (Key No. 10)
115/230 Volt			
P4RA6E-186L	1	A100ELL	C105-238P
P4R6E-187L	1	A100EHL	C105-238PB
P4RA6F-187L	1-1/2	A100FLL	C105-238PB
230 Volt			
P4R6F-188L	1-1/2	A100FHL	C105-238PDBA*
P4RAA6F-198L	1-3/4	A100F5LL	C105-238PDCA**
P4R6G-189L	2	AE100GHL	C105-238PEBA*
P4RA6G-188L	2	A100GHL	C105-238PDBA*
P4RAA6G-189L	2-1/2	AE100G5LL	C105-238PEBA*
230 Volt 2-Speed			
P4RA6YF-187L	1-1/2	A100FLL-Y	C105-238PB
P4RA6YG-188L	2	AE100GLL-Y	C105-238PDBA

*Uses #17301-0151 impeller screw assembly.

** Uses #37337-6080 impeller screw.

• Not illustrated.

* Models P4R6E, P4RA6E, P4RA6F and P4RA6YF use Part No. C1-271P1.

** Model P4R6E, P4RA6E, P4RA6F and P4RA6YF use Part No. U30-542SS.

*** Model P4R6E use Part No. 32155-4071.

P4R SERIES
DURA-GLAS II POOL PUMP
208-230/460V 3 Phase Models

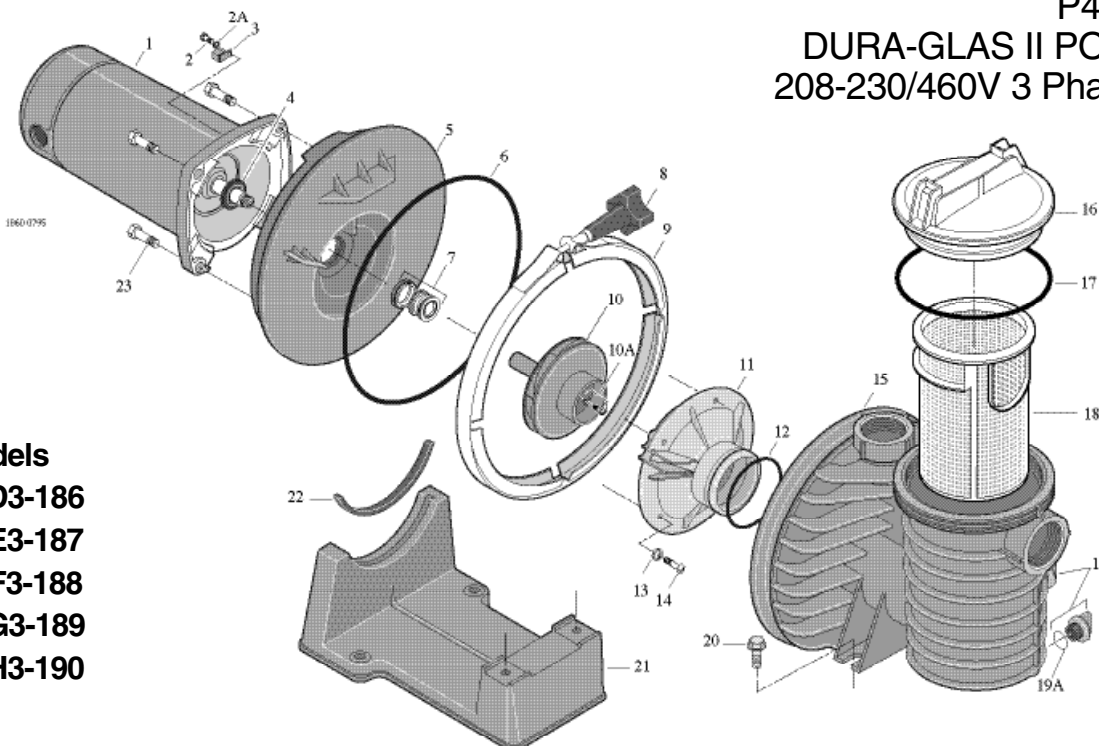

Models
P4R6D3-186
P4R6E3-187
P4R6F3-188
P4R6G3-189
P4R6H3-190

REPAIR PARTS LIST

Key No.	Part Description	Qty.	Part No.
1	Motor	1	Chart at Right
2	#10-32 x 1/2" Screw	1	U30-692SS
2A	Lock Washer	1	U43-22SS
3	Bonding Lug(#)	1	U17-568
4	Water Slinger	1	17351-0009
5	Seal Plate (includes Key Nos. 6 and 7)	1	C203-194P
6	O-Ring	1	U9-228A
7	Shaft Seal	1	37400-0027S
8	Clamp	1	C19-37A
9	Clamp Knob	1	WC36-22
10	Impeller	1	Chart at Right
10A	Impeller Screw Assembly*	1	17301-0151
11	Diffuser**	1	C1-271P
12	Diffuser O-Ring	1	U9-374
13	#8 Lock Washer	5	U43-21SS
14	Screw†	5	U30-922SS
15	Tank Body	1	C176-59P
16	Trap Cover	1	C3-185P
17	Trap O-Ring	1	U9-375
18	Basket	1	C8-58P
19	1/4" NPT Drain Plug	2	U178-920P
20	Base Screw	2	U30-918SS
21	Base w/Motor Pad***	1	C104-78P
22	Motor Pad***	1	C35-43
23	3/8-16 x 1" Hex Head Screw	4	U30-74SS
•	Motor Nameplate	1	32155-7117
•	Tag, "CAUTION"		61002-0002
•	Tag, "CAUTION, WARNING (Bonding)"		C63-12
•	Nameplate – Pump		U33-174

Parts are common to all models listed except as noted; Key Nos. 1, Motor; and 10, Impeller are listed below.

Model No.	HP	Motor No. (Key No. 1)	Impeller No. (Key No. 10)
208-230/460-3Ø			
P4R6D3-186	3/4	AP100DH	C105-238PA
P4R6E3-187	1	AP100EH	C105-238PBA
P4R6F3-188	1-1/2	AP100FH	C105-238PDBA
P4R6G3-189	2	AP100GH	C105-238PEBA
230/460-3Ø			
P4R6H3-190	3	AP100HL	C105-238PLA

***Model P4R6H3 uses Base No. C104-79P and Pad No. C35-44.

† Models P4R6D3 and P4R6E3 use Part No. U30-542SS.

• Not illustrated.

* Model P4R6E3 uses Part No. 17301-0152.

** Models P4R6D3 and P4R6E3 use Part No. C1-271P1.

Model P4R6H3-190 has no bonding lug assembly, Key Numbers, 2, 2A and 3.

**P4R SERIES
DURA-GLAS II POOL PUMP
200/400V 3 Phase Models**

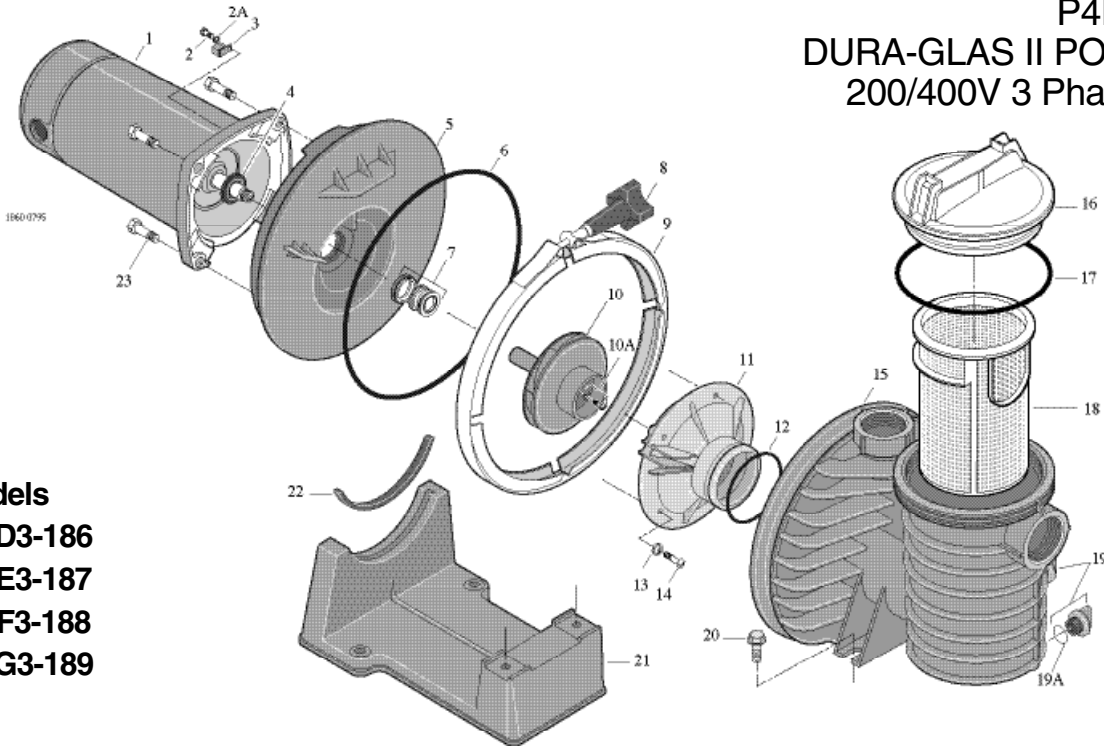

Models
P4R62D3-186
P4R62E3-187
P4R62F3-188
P4R62G3-189

REPAIR PARTS LIST

Key No.	Part Description	Qty.	Part No.
1	Motor	1	Chart at Right
2	#10-32 x 1/2" Screw	1	U30-856ZP
2A	Lock Washer	1	U43-22SS
3	Bonding Lug	1	U17-568
4	Water Slinger	1	17351-0009
5	Seal Plate (includes Key Nos. 6 and 7)	1	C203-194P
6	O-Ring	1	U9-228A
7	Shaft Seal	1	37400-0027S
8	Clamp Knob	1	C19-37A
9	Clamp	1	WC36-22
10	Impeller	1	Chart at Right
10A	Impeller Screw Assembly*	1	17301-0151
11	Diffuser**	1	C1-271P
12	O-Ring Diffuser	1	U9-374
13	#8 Lock Washer	5	U43-21SS
14	Screw***	5	U30-922SS
15	Tank Body	1	C176-59P
16	Trap Cover	1	C3-185P
17	Trap O-Ring	1	U9-375
18	Basket	1	C8-58P
19	1/4" NPT Drain Plug	2	U178-920P
20	Base Screw	2	U30-918SS
21	Base w/Motor Pad	1	C104-78P
22	Motor Pad	1	C35-43
23	3/8-16 x 1" Hex Head Screw	4	U30-74SS
•	Motor Nameplate	1	32155-7117
•	Tag, "CAUTION"		61002-0002
•	Tag, "CAUTION, WARNING (Bonding)"		C63-12
•	Nameplate – Pump		U33-174

Parts are common to all models listed except as noted; Key Nos. 1, Motor; and 10, Impeller are listed below.

Model No.	HP	Motor No. (Key No. 1)	Impeller No. (Key No. 10)
200/400V-3Ø			
P4R62D3-186L	3/4	AP100DH2	C105-238PA
P4R62E3-187	1	AP100EH2	C105-238PBA
P4R62F3-188	1-1/2	AP100FH2	C105-238PDBA
P4R62G3-189	2	AP100GH2	C105-238PEBA

• Not illustrated.

* Model P4R62E3-151 uses Part No. 17301-0152.

** Models P4R62D3, P4R62E3 use Part No. C1-271P1.

*** Models P4R62D3-150 and P4R62E3-151 use Part No. U30-542SS.

STA-RITE®



S454 (Rev. A) 04-13-10